

Biomass steel hot-water boiler for straw bales BTK 40-100 KW
MANUAL for use and maintenance



Prhovačka bb 22310 Šimanovci, Srbija
Tel/Fax. +381 22 480404 +381 63 259422
office@termomont.rs www.termomont.rs

July 11, 2013

Contents

1	Technical data	2
1.1	Boiler dimensions	2
1.2	Technical data chart	2
1.3	On Product	2
2	Recommendations for boiler shipment and storage	3
2.1	Delivery form	3
2.2	What's in the box	3
3	Boiler installation	3
3.1	Boiler placement	3
3.2	Chimney	4
4	Boiler installation	4
4.1	Fitting the boiler to a closed central heating system	4
4.1.1	Installation method 1	4
4.1.2	Installation method 2	6
4.2	Fitting the boiler to an open central heating system.	6
4.3	Filling up the boiler and installation with water	7
5	Boiler operation	7
6	Boiler cleaning and maintenance	8

1 Technical data

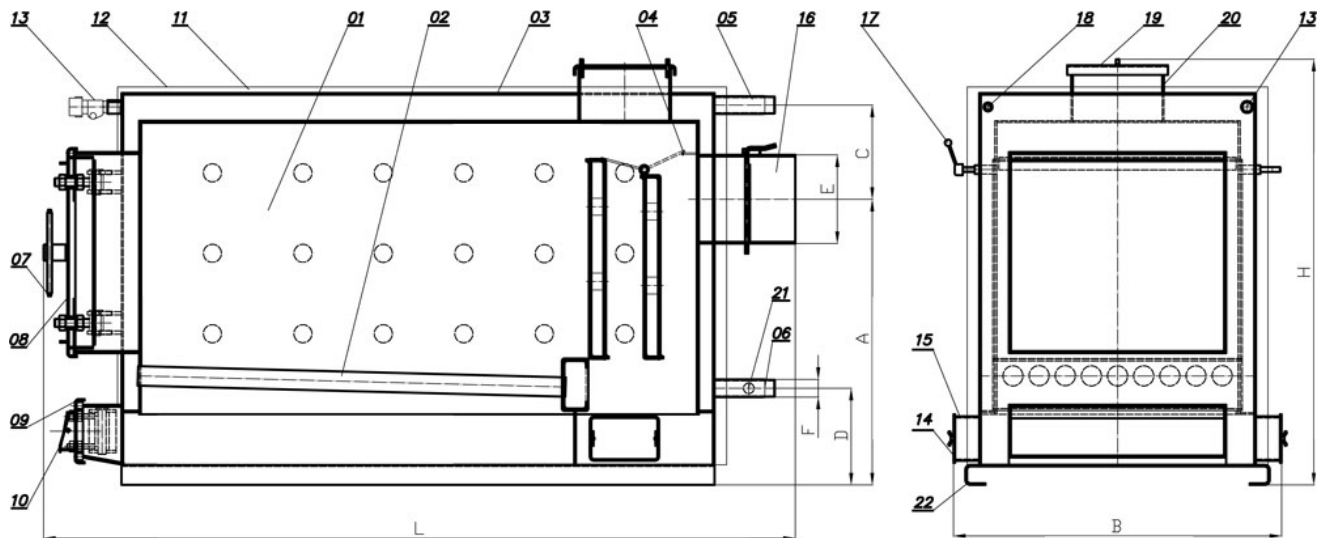

Parts of the boiler: 1. Combustion chamber 2. Grid 3. Boiler 4.Boiler flap 5. Flow line 6. Return line 7. Door handle 8. Door for fuel feed 9. Ash cleaning 10. Primary air control flap 11. Insulation 12. Boiler housing 13. DRaught regulator mounting hole with threads 14. Opening for cleaning - cover 15.Opening for cleaning 16. Flue 17. FLue flap handle 18. Manometer mounting threads 19. Upper opening for cleaning - cover 20. Upper opening for cleaning 21. Drain tap 22. Boiler basement

1.1 Boiler dimensions

Boiler type	Weight (kg)	B (mm)	H (mm)	L (mm)	A (mm)	C (mm)	D (mm)	E (mm)	F (Φ)
BTK 40	470	785	1060	1720	710	235	205	220	5/4
BTK 65	545	815	1060	1870	710	235	240	220	5/4
BTK 100	780	1080	1160	2200	800	240	240	220	2

1.2 Technical data chart

Nominal power BTK* (KW)	40	65	100
Water content (l)	162	184	295
Chamber Volume (dm ³)	335	415	830
Output gas temperature at nominal power (°C)	250	250	250
Temp. regulation range (solid fuel) (°C)	60-90	60-90	60-90
Minimum temp. return line (solid fuel) (°C)	60	60	60
Efficiency	70-80%	70-80%	70-80%
Required chimney height (m)	7-8	7-8	9-10
Required chimney inner diameter (mm)	220	220	250

1.3 On Product

- Solid fuel hot water boiler for central heating systems – specially constructed to burn whole straw bales;
- Due its increased volume the heating chamber can be fed with more fuel – apart of biomass, longer wood stocks (up to 1 m) or the coal with lower calory value can be used as well;
- The whole boiler is isolated with appropriate mineral wool protection and its door with fire clay (chamotte);

- Specific construction allows double pass (draught) of heating air – efficiency depends on the type of the fuel used, but lies above 70 % in any case (up to 80 % for soya straw);
- In order to allow constant and most efficient working circle, use of an additional tank “Termomont AT” (heat accumulator) is strongly recommended;
- Boiler is easy to clean with included cleaning kit;
- Each boiler is tested on 6 bar test pressure;

2 Recommendations for boiler shipment and storage

2.1 Delivery form

The boiler comes in three parts, boiler chamber, pellet storage and the boiler housing packed separately. Chamber is wrapped with plastic sheet, and upper door containing fireproof glass should have a small styrofoam protection sheet. The whole set is transported on wood pallet.

The boiler must always stand in its vertical position. The rotation of the boiler during the shipment or installation represents a serious risk and can lead to damaging the boiler. It is forbidden to stack boilers vertically one onto other.

The boiler can be stored only in closed rooms with no atmospheric influence. The humidity in the storing room also must not exceed the critical value of 80%, so as not to create any condensate. The temperature of the storing room must be in the range of +/- 40 ° C.

2.2 What’s in the box

The following parts are supplied together with the boiler:

- Cleaning kit
- Warranty note

3 Boiler installation

3.1 Boiler placement

The boiler room should have air-conditioning. The boiler should be mounted in the boiler room permitting access to all its parts as shown below: (L = 1200 mm for all TKH models)

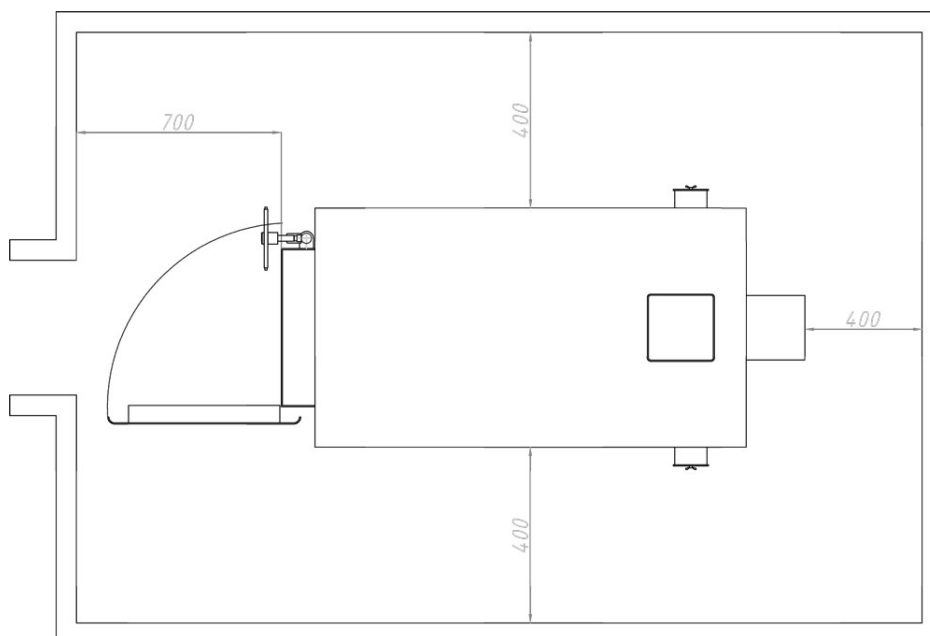

3.2 Chimney

Boiler connection to the chimney is shown in the figure:

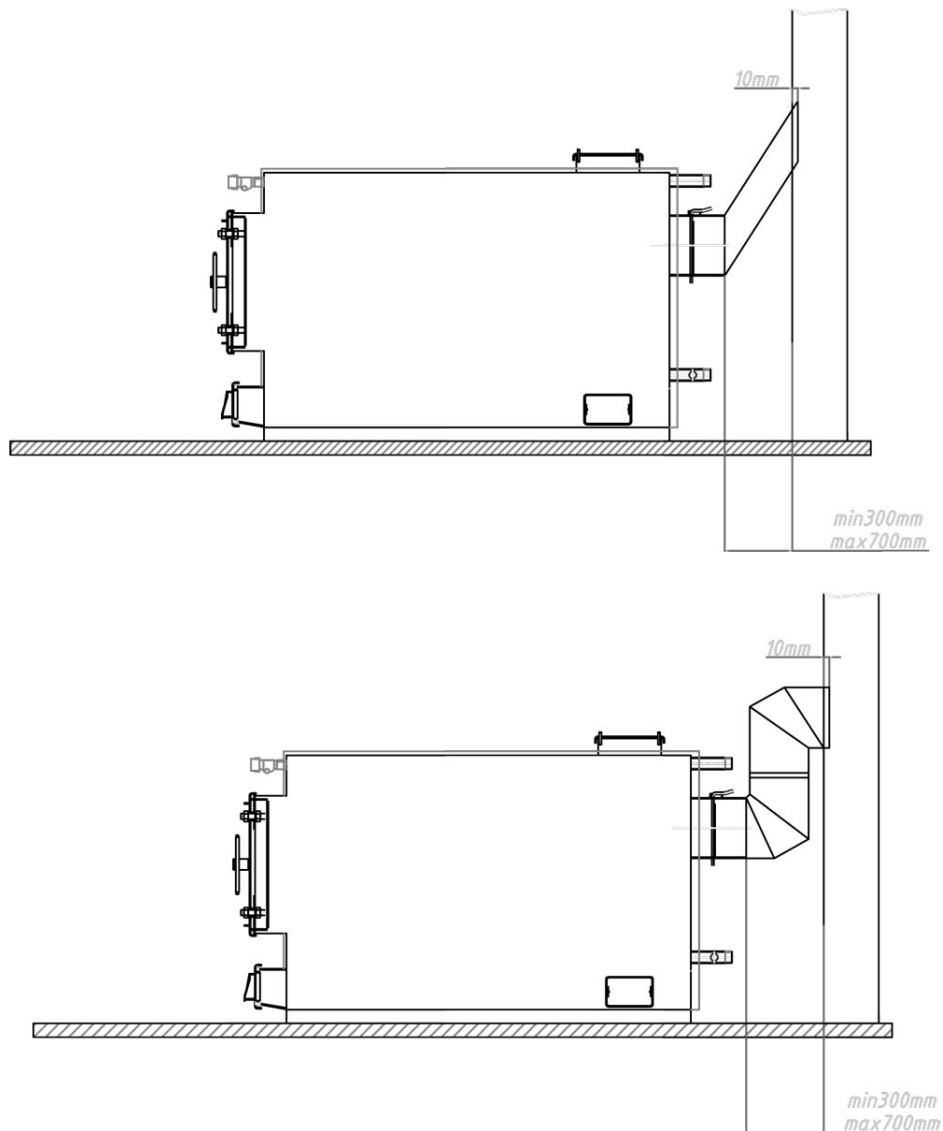

Proper dimensioning of the chimney is a very important premise for optimum boiler performance. The purpose of the chimney is to take out the products of combustion but also to secure necessary air draught in the boiler. The graph shows how to choose the necessary height for the chimney as a function of chimney opening. Proper chimney insulation is very important and should be at least 50 mm thick.

Depending on the necessary draught of the boiler, the cross section and the height of the chimney are determined. Please advise technical material given by chimney producer. Minimum chimney height for TKH wood boilers is 15 m. Estimate for chimney height is given in the technical data chart. Round chimney made of stainless steel modules is recommended in order to keep the condensation influence low.

4 Boiler installation

4.1 Fitting the boiler to a closed central heating system

Depending on the position of the boiler in relation to the pipe-work and the radiators – the installation can be carried out using one of two methods.

4.1.1 Installation method 1

If the boiler is positioned on the same level or higher than the pipe-work and radiators.

Each of the following items of equipment shall be fitted along the flow line:

1. Aeration vessel.
2. Safety valve (spring valve is recommended).
3. Expansion vessel.
4. Boiler valve.

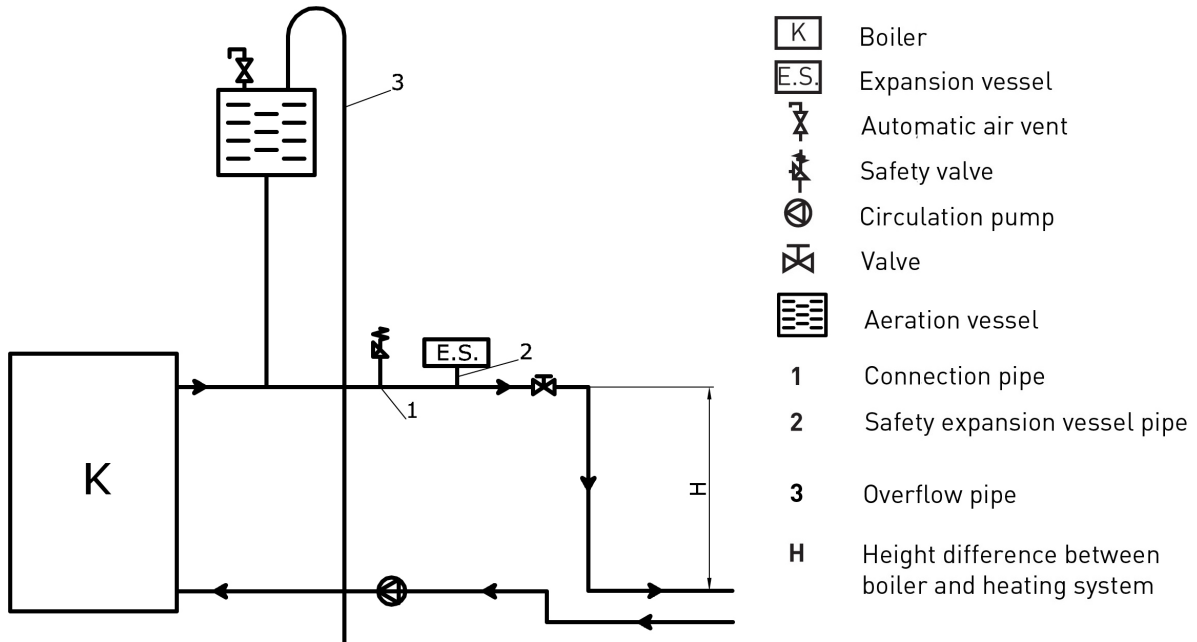

Aeration vessel to be fitted at highest point of the system at top of boiler outlet. This should include an overflow system with valve to discharge air from the boiler to prevent overheating.

A float operated valve allows water into a cistern fitted with an overflow pipe. When the system is filling, the valve remains open. When the system is full the valve closes.

Temperature of hot water within a storage system. Irrespective of the type of fuel used for heating, the temperature of the water at any point within a hot water storage system should not exceed 100 °C and appropriate vent pipes, temperature control devices and other safety devices should be provided to prevent this occurring.

Safety Pressure Valve (PSV). The safety pressure valve must always be positioned and mounted close to the boiler. It must be easily identifiable and allow for easy access. The safety pressure valve must be set to a nominal pressure of 2.5 bar. The valve must open and operate smoothly at 2.5 bar. Diameter for the aperture at the seat of the valve must be at least 15mm. Connecting pipe-work to the boiler must be as short as possible. Welds, joints or any possible blockage to this pipe-work must be prevented.

Bends in the pipe-work should be avoided if possible. Unavoidable bends should be at diameter $r > 3D$ (D = radius of curvature) and less than $\alpha > 90$ °C.

Closed expansion vessel. The closed expansion vessel shall be fitted close to the boiler. Connecting pipe-work should be as short as possible. Fit the expansion vessel in horizontal alignment to the pipe to ensure equal distribution of pressure. The volume of the expansion vessel is determined by the output/capacity of the boiler. A ratio of 1 kW:1 litre should be used.

The safety pressure valve and the expansion vessel should be fitted in close proximity to each other, in the following order: expansion vessel closest to the boiler, followed by the safety pressure valve.

It is also recommended to mount a dirt remover on the RETURN line.

In the event of power failure and the boiler fails to operate correctly – any sudden increase of pressure will be controlled first by the expansion vessel, on any further increase in pressure the safety pressure valve will open.

Great care must be taken to ensure air does not enter the boiler.

4.1.2 Installation method 2

To be used in the case of the boiler being positioned and installed at a lower level than the installed pipe-work and radiators.

As shown on Figure, following elements are connected along the FLOW:

1. Automatic air vent
2. Safety valve
3. Circulation pump (separated with ball valves on each side so that it can be easily replaced if necessary).

For safe operation info on additional equipment such as expansion vessel and safety valve please refer to manuals to be delivered with such products.

This air vent valve must be open when first filling the boiler on installation completion.

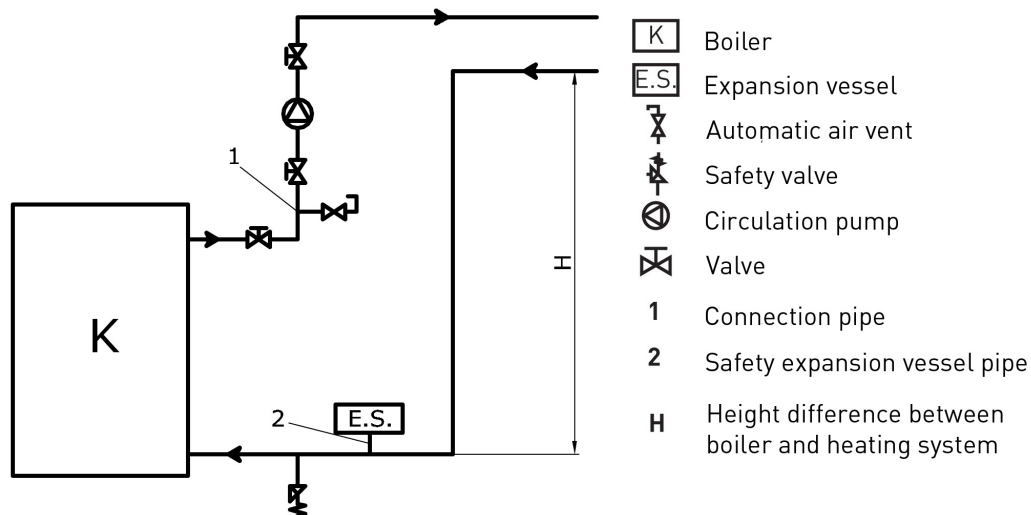

4.2 Fitting the boiler to an open central heating system.

The connecting scheme of an open central heating system is depicted on the figure.

Open expansion vessel is connected to the hot-water distribution pipes (FLOW and RETURN) as shown on Figure – with an additional OVERFLOW pipe output plus CIRCULATION pipe (to prevent freeze during winter months).

Please note that no additional items shall be connected to the open expansion vessel – especially not valves.

The size of expansion vessel is deducted from the following equation:

$$V = 0,07V_{water}(l)$$

$V_{water}(l)$ is the water volume in the entire installation.

Open expansion vessel is to be positioned vertically above the highest heating element.

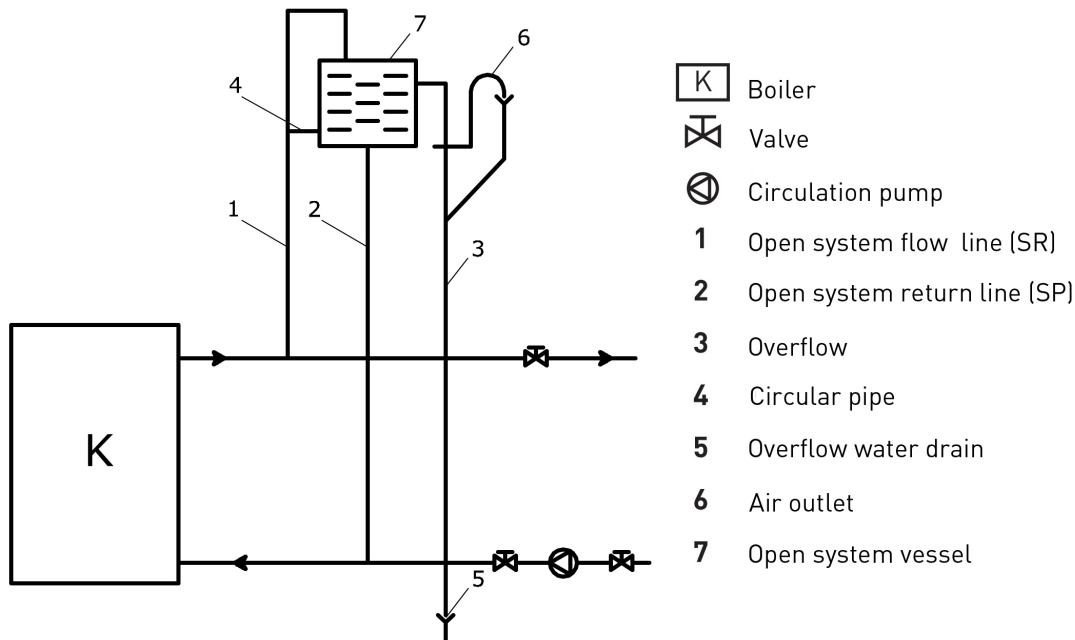

4.3 Filling up the boiler and installation with water

Filling is done using the drain tap valve (to be found on the return line close to boiler). The filling process is done when no air is coming out through automatic air vent and pressure gauge is showing the value between 1,5 and 2,5 bar (closed systems). Air vent is to be set at the highest point of the (closed) central heating system. If the pressure is below 1,5 bar the filling process must be repeated.

For open systems, working pressure depends on the overall height of the system and the open expansion vessel (1 bar for each 10 m is an estimate).

After the filling process is done, it is obligatory to close the drain tap valve, close the water supply to the water-filling pipe and detach the water-filling pipe.

An expert should be entrusted with the mounting of the heating and the initial operation. This must be a person who will take over the responsibility and guarantee the correct operation of the boiler and of the complete central heating system. In the case of an incorrectly planned system with manifesting deficiencies caused by the respective person's incorrect installation of the system, which can again lead to an incorrect operation of the boiler, the complete liability for the material damage and potential new costs arising in relation to it is borne exclusively by the person who was entrusted with the mounting of the central heating system, and not by the boiler manufacturer, sales representative or seller.

5 Boiler operation

First putting into operation is performed exclusively by a skilled person. Before putting in operation please make sure that:

- boiler is connected on central heating installation properly
- boiler is connected on electric installation properly (when using pellet or oil burner)
- fuses are chosen properly according to boiler's electric scheme and KW power

- there is no air in the central heating installation and pressure is within range
- proper working cycle for circulation pump is chosen.

Heating by solid fuel (manual operation) can be performed in two ways:

1. Heating from above – put coal (or wood) over the fireplace pipes (“grid”) (no ash should be present). The draught regulator is at the maximum position. Using a tiny piece of wood or coal, light a fire on the top. When the fire begins to burn, draught regulator is set on desired temperature / position.
2. Heating from below – put small amount of solid fuel over the fireplace pipes (“grid”) (no ash should be present) and set up a fire. The draught regulator is at the maximum position. When the fire begins to burn, add larger amount of fuel and set draught regulator on desired temperature / position.

Make sure that lower boiler doors are closed during boiler use.

In case of an uncontrolled increase of pressure and temperature of the water in the boiler, due to various reasons (such as power failure causing interruption of the circulation pump operation, circulation pump defect, uncontrolled entry of air into system) close all air supply to the boiler or eventually take the fire out if the safety conditions allow that (there are no inflammable materials in the area). In case of power failure put the draught regulator in the zero position and the flap on the boiler chimney take-up in the closed position.

It is obligatory to pay special attention that the pressure inside the installation is within range ($> 1,5$ bar for closed systems). If the pressure is below the critical value, stop the boiler operation and refill the system when the boiler is cold.

The water hardness may not exceed the recommended value. If you heat the boiler using coal, depending on the kind of coal and quality of combustion, boiler is to be cleaned at least every 30 days. Dirtier the boiler, the efficiency of the system is smaller.

It is not allowed to extinguish the fire in the boiler artificially, it is forbidden to sprinkle the water inside the heating chamber. After the heating season boiler should be cleaned from ash and soot and the chamber should be treated with some protection agent against corrosion.

In case of any mechanical problem (the draught regulator is blocked, or the circulation pump is defect) stop the boiler operation first – only when the boiler is cold, reparation action can be undertaken.

6 Boiler cleaning and maintenance

It is recommended that the boiler is cleansed from ash once to two times weekly. A detailed cleansing of the boiler should be done once a month and also when the heating season ends. Regular maintenance extends the service life of the boiler. Cleaning is to be done through upper and lower door of the boiler but also using the opening on the back side (chapter 1, position 16).